

Turbine Flowmeter VISION 2000 [®]

For low viscous and non-aggressive liquids, for low flow rates



Low Cost

Small, compact size

Operates in any position

High operating pressure

**Temperature range
-20°C up to 100°C**

High accuracy +/- 3%

Maintenance free

Operating Principle:

Fluid flow causes a bladed turbine inside the VISION housing to turn at an angular velocity directly proportional to the velocity of the fluid measured. As the blades pass a magnetic pickup coil, a frequency signal is generated.

Each pulse is equivalent to a discrete volume of fluid. The frequency pulse is directly proportional to the turbine angular velocity and the flow rate.

The large number of pulses gives a good resolution. As the mass of the turbine are very small the response time is very short. It is not necessary to install a straight length of pipeline at the up streamside.

The simple mechanical construction of the sensor VISION 2000 guarantees a long lifespan without any loss of accuracy. Pressure pulses do not affect the measuring system

Liquid media:

Water, Purified-Water, Water-based liquids, Beverages
Alkaline solutions, Oil, Gasoline, Diesel, Paints, Ink...

Applications:

Food Industry:

Coffee machines, Vending machines,
Dispensing systems, Bakery machines,
Steamers...

Medical Applications:

Sterilizers, Slide staining, Dental water jets,
Dialysis machines...

Chemical- und Pharma Industry:

Dosing systems, Bottling plants...

Industrial applications:

Cooling systems, Washing machines and
plants, Dosing systems, Water treatment units,
Filter monitoring systems, Solar plants...

Automotive:

Fuel consumption measurement, Fuel injection
systems...

Specifications:

Turbine Type	2006 4F44	2006 2F66	2008 4F17	2008 4F23	2008 4F44	2008 2F66
Flow rate (l/min)	1 - 10	0,5 - 5	2 - 35	1 - 25	1 - 15	0,5 - 7,5
K-factor (PPL)	3300	6900	750	1000	2200	4700
Frequency (Hz)	55-550	57,5-575	50-437,5	25 -416,67	36,67-550	39,17-587,5
DN mm	6	6	8	8	8	8

Operating pressure	25 bar					
Burst pressure	200 bar					
Inlet / Outlet ports	G 3/8"		NPT 3/8"		O-Ring	
Operating temperature	- 20°C to +100°C					
Accuracy	+/- 3% of Reading					
Repeatability	< 0,50 % under the same operating conditions					
Viscosity	up to 16 cSt					
Electrical connection	3 Pin (2,8 x 0,5) Mini DIN Connector, EN 60529					
	Round Cable 3 x AWG24 with free cable ends					
	AMP Faston 2,8/6,3 x 0,8 (on demand)					
Filter	20 to 40 Microns recommended					
Input power	5 – 24 VDC					
Power consumption	~ 8 mA					
Output (Hz)	NPN Sinking Open Collector					
Output current	Max. 20 mA (Pull-Up resistor required, see wiring diagram)					
Materials	Housing			PA12 Grilamid TR55		
	Turbine			PA12 Ferrite		
	Bearings			PTFE		
Weight	~ 15 g					
Approvals	KTW an W270 Approval for drinking water, FDA approved materials					

Pressure drop Δp in bar, with water flow at 20°C (68°F):

Type	2006 4F44	2006 2F66	2008 4F17	2008 4F23	2008 4F44	2008 2F66
0,5 l/min	-	-	-	-	-	-
1 l/min	~ 0	~ 0	~ 0	~ 0	~ 0	~ 0
1,5 l/min	-	-	-	-	-	-
2 l/min	0,06	~ 0	~ 0	~ 0	0,05	~ 0
5 l/min	0,20	0,12	~ 0	0,05	0,20	0,05
10 l/min	0,70	0,40	0,12	0,17	0,40	0,20
15 l/min	-	0,90	0,25	0,27	-	0,40
20 l/min	-	1,30	0,45	0,48	-	0,70
25 l/min	-	-	0,60	0,65	-	-
30 l/min	-	-	0,92	-	-	-

Dimensions (mm) / Wiring:

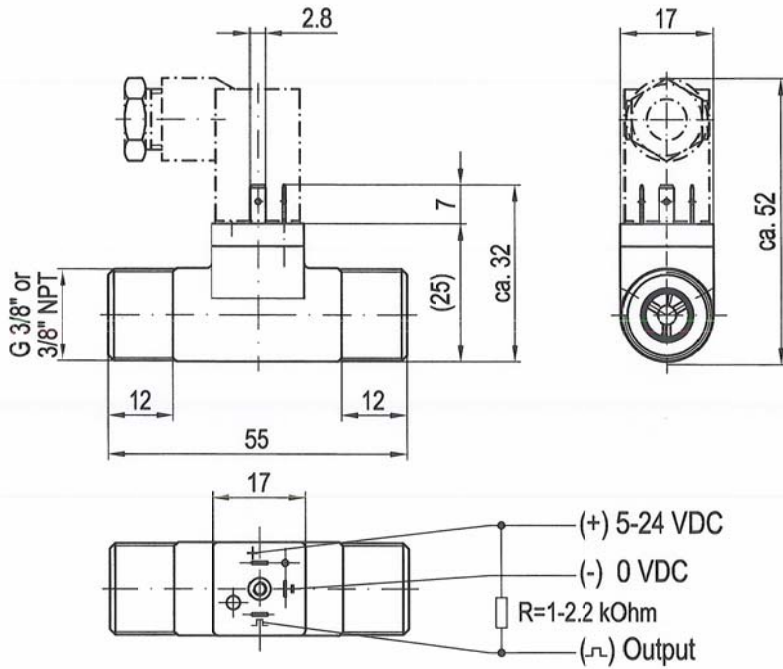

G 3/8" or 3/8" NPT

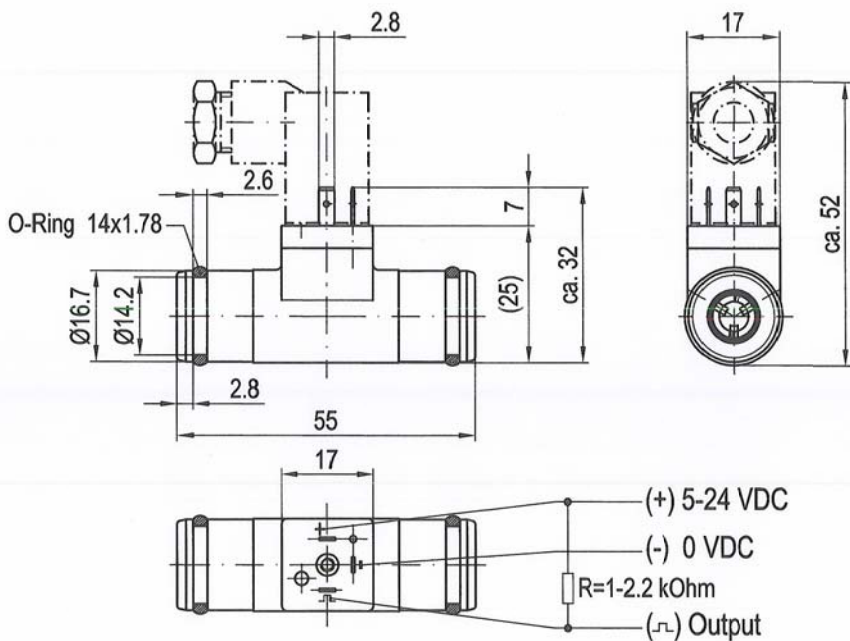

O-Ring

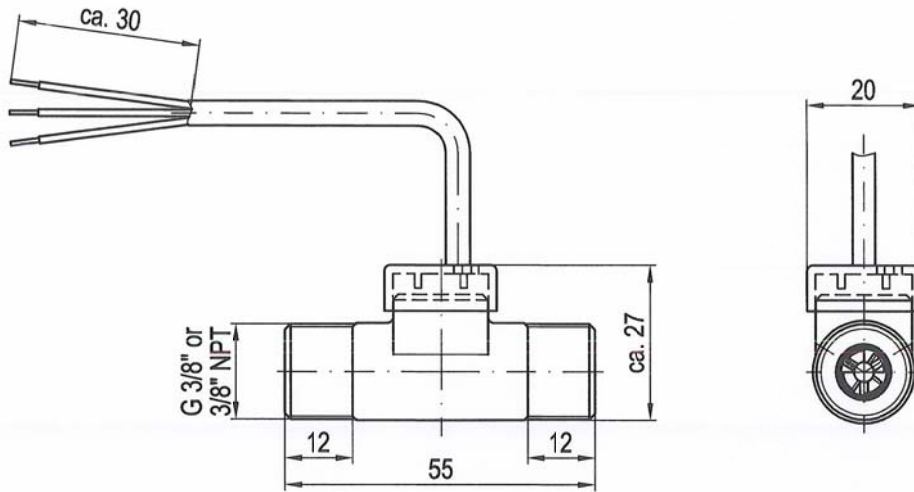

(+)Rot/Red
5-24 VDC
(-)Schwarz/Black
0 VDC
(~)Braun/Brown
Output

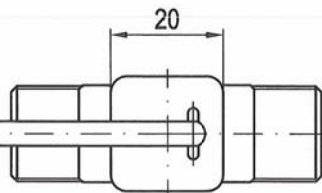

G 3/8" or 3/8" NPT with round cable 3 x AWG 24 and free cable ends

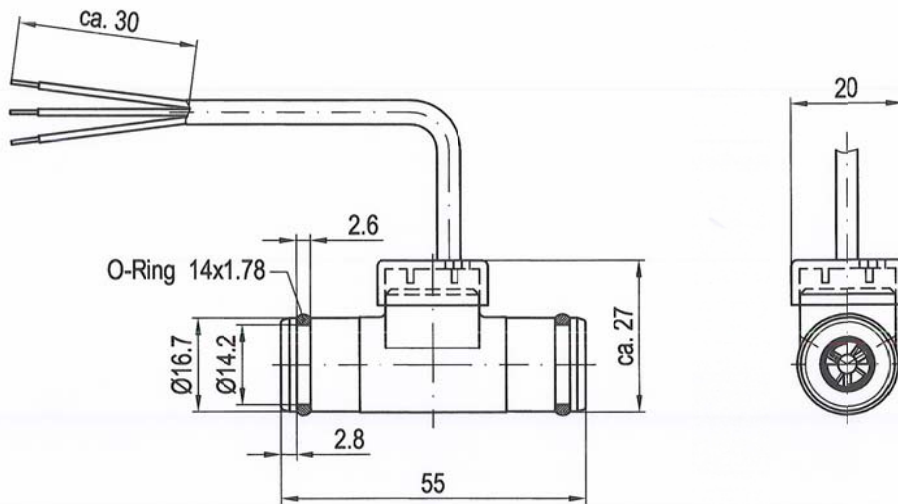

(+)Rot/Red
5-24 VDC
(-)Schwarz/Black
0 VDC
(~)Braun/Brown
Output

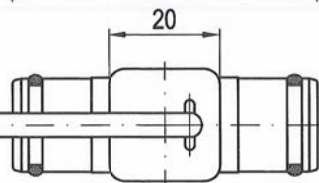

O-Ring, with round cable 3 x AWG 24 and free cable ends

Order code:

Turbine Type	4F44	2F66	4F17	4F23	4F44	2F66
Flow range (l/min)	1 - 10	0,5 - 5	2 - 35	1 - 25	1 - 15	0,5 - 7,5
K-Factor (PPL)	3300	6900	750	1000	2200	4700
G 3/8"	46510	46510	46500	46500	46500	46500
NPT 3/8"	46512	46512	46502	46502	46502	46502
O-Ring	46521	46521	46520	46520	46520	46520

Example:

46510 - **163** - **4F44** - **1**

Housing

See chart

El. Connection

163 = DIN Connector
164 = AMP Faston*
165 = Cable

Turbine type

See chart

Cable length

1 = Cable length 1m
2 = Cable length 2m
3 = Cable length 3m

*On demand

Installation and Operation Instructions:

- Check compatibility of media with sensor material.
- Solid ingredients in media require a filter in front of a sensor. Avoid absolutely fibrous soiling.
- Install sensor into properly cleaned pipeline only.
- Check electrical connection according to the electrical wiring plan.
- Do not exceed the specific indications.
- The *VISION 2000* [®] is a volumetric measuring device; any air/gas in the liquid will be included in measured volume.
- Correctly installed, the sensor works entirely maintenance free.
- Do not blow out the turbine flowmeter with compressed air, the bearings can be damaged.