

# LT100

Submersible transmitter for level measurement in liquids



Level transmitter with submersible probe in stainless steel for level measurement in vessels where pressure connection in the bottom of the vessel is not possible or desirable. For example pump pits, reservoirs or plastic tanks.

- LT100 has microcomputer based electronics.
- HART communication.
- Accuracy 0,1 %.
- Configuration through HART communication from PC with the program PI100 or with a standard hand held HART terminal.
- Withstands mediatemperatures up to 80 °C continuously.
- Well tested and approved for EExia according to ATEX and CE (EMC and PED).
- Lightning protected (option). Fullfills the demands for Class 1 testing according to IEC61643-1, 5 kA (10/350 uS). This means that the transmitter can withstand a stroke of lightning close to the supply/signal cables. (Not available together with EExia approval.)
- Stainless steel measurement probe with a rugged Hastelloy C 276 diaphragm (others on request).
- Embossed diaphragm, insensitive to particles and contact. Can easily be cleaned without deformation.
- Big span turn down ratio. Down to 1/30 of sensor limit.



## Types and order codes:

The transmitters order codes for different configurations can be found from the table below.

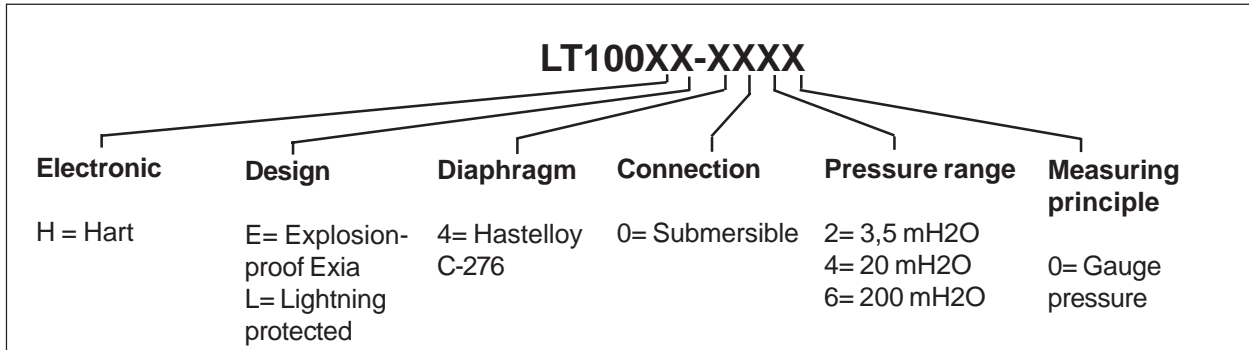

### Ordering example

Lightning protected level transmitter with submersible measuring probe, 10 m cable and calibrated range 0-1,5 m water level will have the order code: **LT100HL-4020** with calibrated range 0-1,5 mH2O

## Description

LT100 is a level transmitter for applications where pressure connection in the bottom of the vessel is not possible or desirable, for example pump pits. LT100 consists of a measurement probe with the diameter 31 mm. The probe has a Hastelloy C-276 measuring diaphragm for highest corrosion resistance (other material as options). The probe are suspended in its connection cable. Standard length for the probe cable is 10 m, but can be delivered in length up to 500 m, max range 200 mH2O (cable length over 500 m on request). Connection of the probe cable can be done in optional connection box. A specially designed connection box can be delivered as an accessory. This box is equipped with an appropriate connection for the probe cables atmospheric vent tube. Its also possible to equip this box with a local display. LT100 can as an option be delivered with a good lightning protection (see next page for description). LT100 can as an option also be delivered in intrinsic safe design, EExia.

### Function

LT100 has a piezoresistive sensor connected to the media by means of a diaphragm and a capillary tube. The media pressure acts on the diaphragm

and is transferred to the sensor through a pressure intermediate oil. Since this oil completely fills the volume between the diaphragm and the sensor the diaphragm movement is very small when the pressure changes. Since the diaphragm are embossed to the surface underneath it is very insensitive to particles and contact. The capillary tube protects the sensor from high overloads because of short pressure shocks. To obtain atmospheric pressure on the back side of the sensor (for reference pressure) it is connected to the surrounding through a capillary tube inside the probe cable.

LT100 has microcomputer-based electronics, which communicate with the outside world with 4 to 20 mA signal as well as HART communication. The electronics measure and converts the output signal from the pressure dependent sensor bridge to digital values. Furthermore, the total resistance of the sensor bridge is measured and these values are converted to digital temperature values.

The electronics perform compensation for temperature drift of the sensor by means of compensation values entered at the factory calibration and at the same time the temperature measurement is also calibrated. Compensation for the non-linearity in the sensor is done in the same manner.

Different kinds of transfer functions, such as linear, square root, curves..., can be selected. The electronics perform the calculation for the selected transfer function and then the digital value is converted to analogue for the 4 to 20 mA current loop. The digital value can also be read via HART communication in optional engineering units, percentage or current.

LT100 can be configured/calibrated fully by means of a hand terminal or a PC via HART communication.

### To consider

Don't expose the diaphragm to unnecessary damage (even though its very robust and insensitive). Don't descend the probe so that it stands on the bottom of the vessel. Highest media temperature is +80°C. Make sure that the vent tube is connected to the surrounding atmosphere without the risk of plugging. If the media are turbulent or flowing fasten the probe appropriately.

### Lightning protection

As an option LT100 can be equipped with lightning protection. The transmitter will then have the code LT100HL where L indicates "Lightning protected". This option can not be combined with the

intrinsic safe option (see below). The lightning protection is built in at the factory. No external changes or external components are needed.

This option must be made to order, it can not be built in afterwards.

The protection is designed to withstand a lightning stroke close to the probe cable and connection cables but can not withstand a direct stroke. The protection is designed to meet the demands for Class 1 testing according to IEC61643-1 5 kA (10/350 uS).

This protection is normally enough in most applications. In specially exposed installations, where there is high risk for direct strokes, the protection ought to be reinforced.

The lightning protection is built up as a three step protection. The pulse that enters the transmitter is caught by two varistors, three transient protection diodes and a double surge arrester.

The probe cables shield must be appropriately grounded for the protection to fulfill its purpose.

### Intrinsic safety, EExia

LT100 can as an option be delivered in intrinsic safe design, EExia IIC T4, according to ATEX by NEMKO. The transmitter will then have the code LT100HE where E indicates "EExia".

This option can not be combined with the lightning protected option (see above).

## Connection and adjustment

### Connection

The probe cables consists of 2 wires, shield and a vent tube. The wires is colour marked:

White	Signal/supply +
Brown	Signal/supply -
Shield	Ground
Vent tube	Atmosphere

On the Vent tube there is a Fluid filter mounted.

### Connection box

A specially designed connection box, BOX100, can be delivered as an accessory. The box is equipped with cable glands and terminals for connection of the probe cable and the signal/supply cable.

The box can also be equipped with a local display.

The box is equipped with an appropriate connection for the probe cables atmospheric vent tube. This connection does not affect the tightness of the box. Protection class IP67. The vent connection is design so that high pressure water from for example cleaners not can enter the vent or the box.

### Display

The box can also be equipped with a local display. The display can show the the signal in optional engineering units, for example mWc or mH2O. Unit and limits is made to order.

The display is connected in series with the signal/supply cable and is feed by the current loop.

### PI100

PI100 is a software tool on CD-ROM for Windows95/98/2000/XP and Windows NT for configuration, calibration and documentation.

PI100 contains a database with available transmitter types. The program can configure transmitter specific values and perform maintenance, output signal and factory calibration. Furthermore, PI100 performs copying of current configuration, backup on to hard disc, transmitting/receiving via

### Adjustment

Adjustments can be done through HART communication. Connect the HART modem or a hand terminal over a 470 ohm (min 250 ohm) resistor. Use the program PI100, a generic program or the HART hand held terminal for adjustments.

All parameters can be adjusted, for example span, zero, damping etc.

standard HART communication and a self-test with alarm functions.

PI100 contains online presentation of help functions and data sheets.

### Hand terminal

For parameter settings a hand terminal of HART type can be used.

### Approvals

LT100 is CE approved according to the EU directives for pressure equipment, PED, and EMC.

LT100HE is explosionproof approved, EEx ia IIC T4, by NEMKO (according to the EU directive ATEX).

The pressure intermediate oil is a FDA approved silicon oil.

The upper end of the probe (where the cable enters) is equipped with a R3/4" thread for connection of a pipe or a hanger.

### Size

Probe size:

Diameter	31 mm
Length	210 mm

Cable:

Length (standard)	10 m
(max 100 m, special design)	500m)
Diameter	6,5 mm
Area	0,75 mm <sup>2</sup>
Vent tube (diam.)	2,3 mm

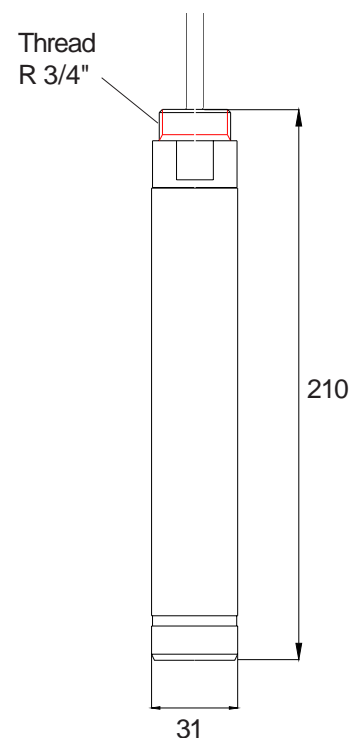

## Technical specification LT100:

<b>Type:</b>	Electronic submersible level transmitter with microcomputer based electronics	<b>Series resistance:</b>	R kohm = (Supply voltage - 11)/20. For HART communication min 250 ohm
<b>Function:</b>	Directly connected transmitter with piezoresistive sensor	<b>Series resistance dependance:</b>	Better than +/- 0,1%
<b>Operating range:</b>	From -100% to 100% of upper sensorlimit	<b>Supply voltage dependance:</b>	Better than +/- 0,1%
<b>Span:</b>	Adjustable between upper sensor limit and 1/30 of this.	<b>Temperature dependance:</b>	Better than +/- 0,1% of max range. (From -10 to +70 degrees C.)
<b>Zero:</b>	Adjustable between -100% and 100% of upper sensor limit	<b>Long time stability:</b>	Better than 0,08 % per year.
<b>Overload:</b>	3,5 mH2O: Max 25mH2O	<b>Vibration dependance:</b>	
	20 mH2O: Max 60 mH2O	Perpendicular to the diaphragm:	Max +0,3 kPa/G
	200 mH2O: Max 600 mH2O	Parallell to the diaphragm:	Max +0,02 kPa/G
<b>Material:</b>	Diaphragm: Hastelloy C-276 (certain coatings on request)	<b>Repeatability:</b>	Better than +/- 0,1% of max range.
	Other media touched parts: Stainless steel SS2353	<b>Accuracy:</b>	Better than +/- 0,1% of max range (including nonlinearity, hysteresis and repeatability).
	Cable: Polyurethane	<b>Electrical connection:</b>	Lose wires
<b>Ambient temperature:</b>	-20 to +80 degrees C	Wire area:	0,75 mm <sup>2</sup>
<b>Damping:</b>	0,1-10 sec. At delivery 1 sec	<b>Encapsulation:</b>	IP68
<b>Media temperature:</b>	Max 80 degrees C	<b>Electrical safety:</b>	According to EN 60204-1
<b>Output:</b>	4-20 mA, two wire connection, signal proportional to the pressure. Max current at overload 22,5 mA. HART communication	<b>EMC:</b>	According to EN 61326-1-2-3
<b>Supply:</b>	9-55 V DC	<b>Intrinsic safety (option):</b>	EExia IIC T4 (NEMKO) according to ATEX
<b>Filling liquid:</b>	AK100, food approved siliconoil (FDA approval)	<b>PED:</b>	According to 97/23/EG
<b>Weight:</b>	700 g including 10 m cable.	<b>Lightning protection (option):</b>	Class 1 testing according to IEC61643-1. 5kA (10/350 uS).